

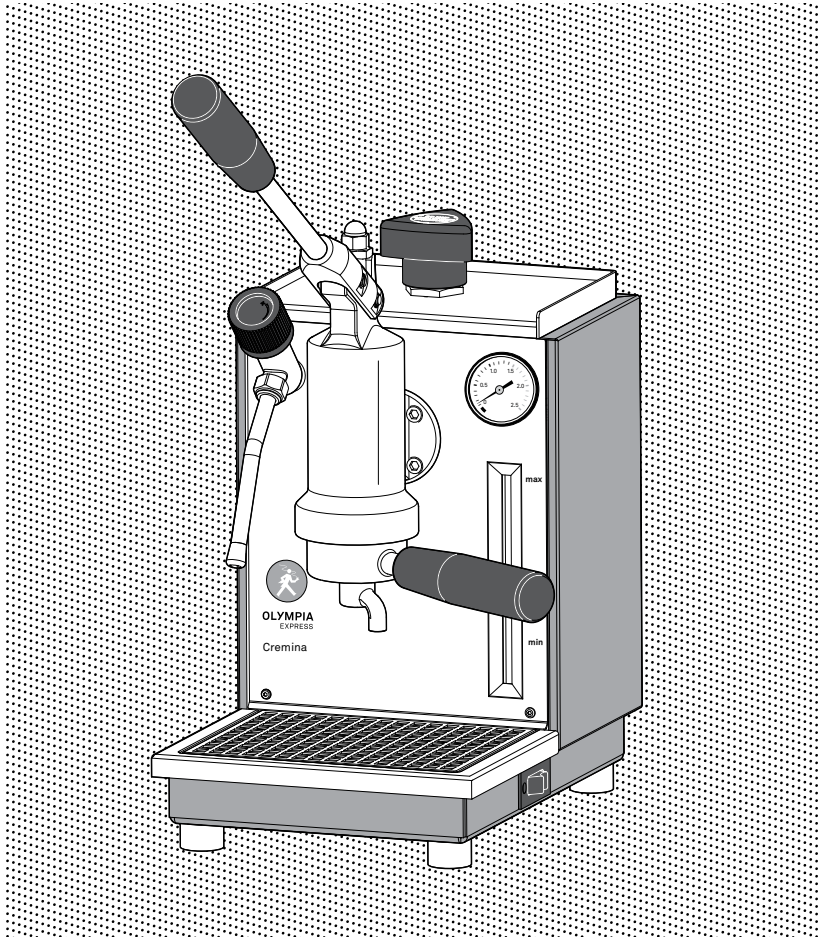

OLYMPIA
EXPRESS

Cremina SL Owner's Book





Glarnerland

Cremina Owner's Book

User manual
Product information
Tips for Baristas

.....
OWNER

.....
CREMINA N°

.....
DATE OF PURCHASE



Dear Olympia Express Customer.

From its roots in northern Italy, the passion for the drink has gained popularity throughout the world. Espresso for everyone, for the filter coffee drinkers in the European north to the tea nations of Asia.

Products get developed faster and become cheaper in order to cover the ever-growing demand. By purchasing an Olympia Express machine, you have consciously chosen to go down another path: Highest coffee culture and coffee indulgence.

You are looking at a handmade machine, compact and elegant, build from premium materials which do not include error prone electronics. Take your time and dive into the fascinating world of coffee, be inspired to learn the craft of a Barista, using your machine to learn and to perfect your skills: It starts with the choice of the bean, the ideal grind setting, the optimal temperature as well as the water pressure right through to the delicious frothed milk. You will be rewarded with a multifaceted taste experience, which you can vary to meet your 'gusto' thanks to the great variety of espresso roasts and kinds of milk. This is how the relationship between you and the Olympia Cremina SL will stay fascinating and long lasting.

Our espresso machines have been built with Swiss precision for over 90 years. They are to be found all over the world and thanks to the machines' robustness also used in its most remote areas. We are proud of the machines' reputation, which it acquired over the decades and we support our Olympia-Express Family with help and deeds. This support we can also promise you. But first we would like to ask you to read the user manual inquisitively and thorough. Our machines have many characteristics – it is important to know them and you will be rewarded for using them.

We wish you much joy with your Olympia Express.

How to get the most from this owner's book

This instructions manual will provide you with all the information that you need in order to create the best espresso

experience. This manual includes the instructions, notes of safety for the use of the Cremina SL espresso machine as well as a written guarantee (inserted as a card). Furthermore, you will learn of the machine maintenance, choice of coffee beans, water and milk. This document should in addition encourage you to try out a variety of different espresso specialties so do our instructional videos, which can be found on our homepage. We hope that this will encourage you to immerse yourself in the world of coffee.

Important!

Even if you would like to start straight away, please read the safety instructions on pages 08 and 11, in order to enjoy your Olympia Express equipment for a long time.

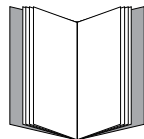

In the middle of the booklet you will find an illustration of the Cremina SL with all its parts (*these elements are italicized* ② *in the text*).

Content

Safety instructions	08
Repair	11

01 Olympia Express

No compromise	13
---------------	----

02 Cremina

50 years of perfection	14
The classic lever-operated espresso-machine	17
Built to last ages	18
Getting started	20
Adjustment, maintenance and cleaning	25
Steam	27

03 Espresso

The importance of the water	30
The importance of the bean	31
Perfect espresso in five steps	32
Judging the result	34
Espresso richness	36

04 First aid and more

Troubleshooting	39
Further reading on espresso	42
Disposal / Recycling	44

Safety instructions.

The Cremina SL espresso machine is designed to be used in the home or in office kitchens.

Please read carefully the guarantee terms on the enclosed postcard. For your own safety and in order not to invalidate your warranty rights, please pay attention to the following safety instructions:

- Read the instructions very carefully before you first start the machine. Keep them with the machine in case any questions should arise.
- Never switch on the machine when the water level has reached “min” or if the boiler is empty. Damage to the boiler element could otherwise occur.
- Please do never open the boiler top ① when the machine is switched on and if the *steam wand* ⑫ has not been emptied completely. Only open the *boiler top* ① when the machine is *switched off* ④. Also open the *steam tab* ③ in order to release built up pressure.
- Never release the loaded *lever* ⑧ except the *lever* ⑧ is in the resting position or ground coffee is in the *portafilter* ⑥.
- The apparatus can only be connected to AC power supply. The allowed voltage can be found on a plate on the bottom side of the machine.
- When the machine is switched on, your Cremina can get very hot. Please only touch the machine at its

handles and make other users aware of the threat of burns and scalds, which can occur for example through the leaking of hot water or the discharge of hot steam.

- Do not allow children to play with the appliance.
- When faults occur while the machine is on, and before all cleaning and maintenance work, remove the plug from the power outlet.
- Only specialists and authorized personnel are allowed to repair electrical goods.
- Never yank the cable in order to pull out the plug, nor touch it with wet hands.
- This piece of machinery may be used by children 8 years of age and over who have been supervised or instructed in the safe use of the equipment and have understood the resulting hazards. Cleaning and maintenance by the user must not be carried out by children unless they are 8 years of age or older and are supervised. The appliance and its connecting cable must be kept away from children under 8 years of age.
- Equipment may be used by persons with limited physical, sensory or mental abilities or lack of experience and knowledge if they have been supervised or instructed in the safe use of the equipment and have understood the hazards involved.

- Never pull the cable over sharp corners and make sure that it is not squashed or bent.
- Do not carry or pull the machine by its cable.
- Only use approved extension cables.
- If the power cord of this machine is damaged, it must be replaced by the manufacturer or its customer service or a similarly qualified person to avoid hazards.
- Do not immerse the appliance in water.
- Clean the machine with a dry or with a moist cloth. Remove plug from the power outlet beforehand.
- Never switch on the machine when the water level has reached “min” or if the boiler is empty. Damage to the boiler element could otherwise occur.
- A thermostat secures overheating and excessive pressure. If the thermostat breaks the electrical current, the *control lamp* ⑤ goes out and only the *on/off button* ④ remains lit. The reset switch is located inside the machine and must be reset by the service dealer.
- Place the machine on a stable and dry surface.
- Packaging, such as plastic bags and foam should be stored out of reach of children, as these materials can be a potential health hazard.

- Do not remove the portafilter when the spring is under tension

The machine can only be used according to the general guidelines in the manual. Misuse or technical changes can be hazardous to your health and your safety. Olympia Express does not take any responsibility if the security guidelines are breached.

Repair.

The repair and maintenance of Olympia Express espresso machines must be carried out by an expert or by the manufacturer.



01



03



02

- 01 "Rest.Bar", Grand-Chêne Lausanne, 1940s
 02 "Olympia Buby", 1961
 03 "Olympia Cremina 67", 1970s

01 Olympia Express. No compromise.

For more than 90 years, perfect materials and workmanship have been top priority at Olympia Express. Each and every tiny detail is constantly rethought and, if necessary, optimized. This is why Olympia Express was the first manufacturer to be using chrome steel water tanks, which meet the strict hygienic and technical demands of our engineers.

The same holds true for the design: "Form follows function". This basic design principle makes Olympia Express products a perfect example of Swiss design.

The concept of sustainability is an increasingly important issue in our society. This has been the guiding principle for Olympia Express for decades. Our machines are durable and repairable, with 50-year old machines still working perfectly and being "vintage" machines, they are much sought after among enthusiasts.

Of course, more machines could be produced but that would mean compromising on the attention paid to quality and precision. However, drinking espresso is to some extent a cultural achievement. Olympia Express has been upholding this culture for generations. The passion for Italian espresso merges with the great tradition of Swiss craftsmanship, resulting in a product, which continues to delight its owner over and over again.

02 Crema.

The Crema gastronomy machine as a role model.

At the beginning of espresso making, when compact water pumps were still a long way off, the quality of the espresso was solely in the wrist of the barista. In the 1950s, or the first time the newly developed brew group with compression spring made the work of the barista easier.

Such machines were now an integral part of the classic café bar. The constant pressure on the coffee powder results in a constant extraction, unlike comparable devices with a pump. For this reason, more lever machines can be found in the café bars today.

The Crema SL (S for spring and L for lever) was developed exactly according to these criteria. According to the wishes and needs of our customers: compact design, perfect workmanship and ease to use.

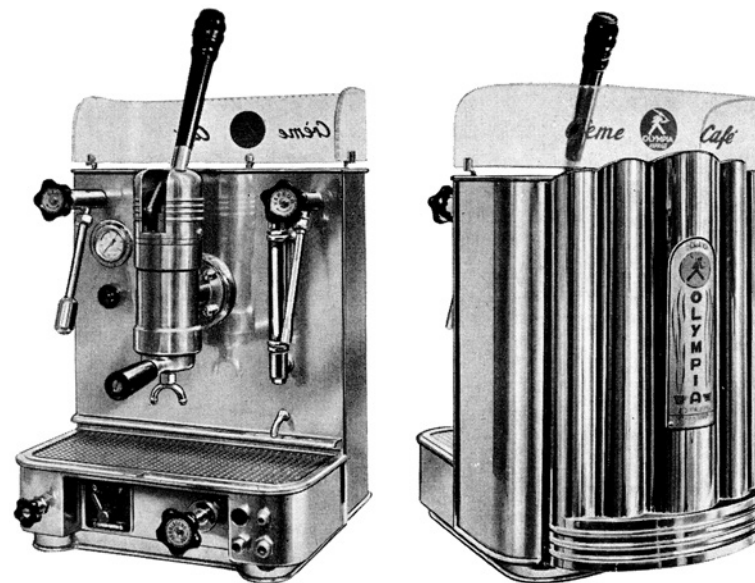

«Crema I-6», taken from a product data sheet around 1950



The lever machine with the little extra.

The Cremina SL combines the tranquility of a hand lever machine with the simplicity of a semi-automatic machine.

So, if you have a soft spot for purely mechanical extraction and do not want to leave constant quality to chance, the Cremina SL is the right choice. Despite the historical model, it is in no way out of date.

The completely redesigned brewing group paired with the solid base of the Cremina give it a unique appearance. Never before a brew group with compression spring has been used on such a compact machine.

With each extraction you can experience how the lever moves constantly and slowly upwards, magically, while a perfect espresso flows into your cup below.

Over 90 years of experience in the production of first-class espresso machines are reflected in the processing and put your daily coffee in the spot light.



Built for a small eternity.

Take a look at the inside: what you will encounter is nothing but stainless steel, chrome, brass and perfect manufacturing.

The brew group, consisting of group head and portafilter are made of brass—and are of course chromed and polished to a high gloss. The steam wand and the steam nozzle are made of chrome steel which increases the longevity of the machine and facilitates the cleaning. The electric boiler, made of chrome steel is filled by opening the top and has a capacity of 1.8 litres—enough for 20 cups of classic espresso. The high-performance tubular heating element has a thermal protection against overheating of the boiler. In order to guarantee a perfect result and longevity, the gaskets used in the Cremina are made of high-tech material. The default pressure is adjusted to between 1.1 and 1.2 bars and the brewing temperature to 92 °C. A compression spring in the brewing head of the Cremina SL ensures constant brewing pressure.

However, not only the inside of the Cremina SL is convincing. Espresso machine purists are also thrilled with its outer appearance: the massive chassis, the sturdy casing and the fittings are of finest quality. The front with its illuminated operation display, as well as the grate and drip tray are made of high-gloss polished stainless steel.

Frame and casing are elaborately lacquered with especially resistant powder coating.

01



02



01 Brew group, chromed brass

02 Portafilter, chromed brass

03 Pressure gauge, chrome steel rim

03





“The Rolls Royce among the one-armed coffee bandits is reminiscent of the design and the material of a spartan Harley-Davidson: simple, powerful engineering and clear outlines. Everything is of the best, highest quality—stainless steel, brass, chrome” (“Neue Zürcher Zeitung”, 2003)

Technical Specifications:

<i>Cremina SL</i>	Width	20 cm
	Depth	27 cm (+ lever 47cm)
	Height	38 cm (+ lever 49cm)
	Weight	13 kg
	Current supply	120 V / 60 Hz ¹
	Cable length	160 cm
	Power input	1000 W

¹ Also available with 230–240 V / 50 Hz / 1000 W (European-Version)

Getting started.

1. Filling the boiler

Open the *boiler top* (1) and fill with fresh water not exceeding the top (“max”) of the *water level indicator* (2). The amount of water in the boiler is therewith close to 1.8 litre. Close *boiler top* (1) properly. Close also the *steam tab* (3) as well (turn to the right). Connect the machine to the power supply. Press the *on/off button* (4); this will light up, as will the *control lamp* (5), indicating that the boiler is heating the water.

2. Releasing air and heating up

As soon as the *control lamp* (5) goes out (after about 10 minutes) and the *pressure gauge* (7) shows 1.1–1.2 bar, open the *steam tab* (3) briefly, allowing the air to be released out of the boiler. The *control lamp* (5) lights up once again briefly, because the machine has to re-heat the water to equal out the decrease in pressure. When the *control lamp* (5) turns off, the machine is ready for use. The *on/off button* (4) is constantly lit, but the control lamp switches on and off; in doing so, you can see that the boiler pressure regulation is working. Depending on the boiler pressure, the *pressure regulator* (17) switches the boiler on or off, allowing the water to be kept at a constant temperature and to prevent a waste in electricity.

3. Preheat the brew group

To preheat the *portafilter* (6), place it in the *brew group* (9) (turn it to the right; figs. 01 and 02) and then lower and lift the *lever* (8) briefly. This action releases water that is then pushed through the piston. To preheat the cups, the top of your *Cremina* is designed to warm up cups.

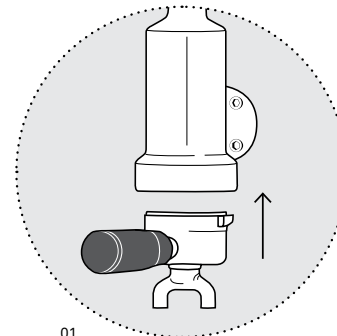

01

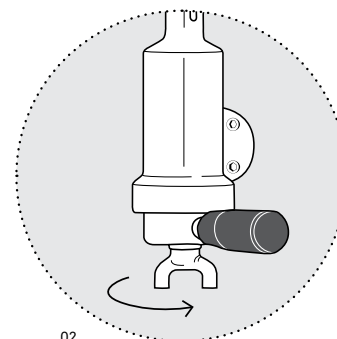

02



(a)



(b)

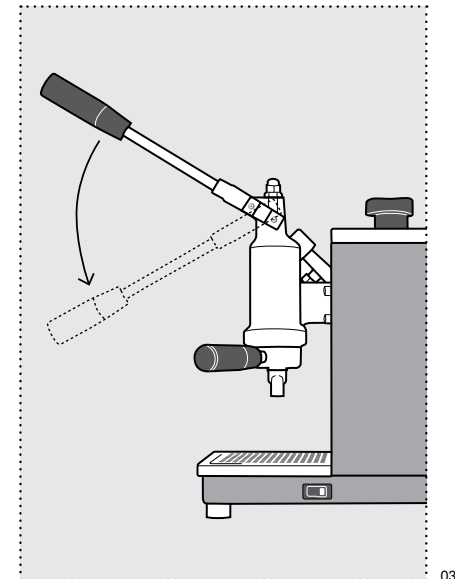

03

01, 02 Place the portafilter

03 Pull down the lever in one movement in order to brew an espresso

4. Locking the portafilter

In order to remove the *portafilter* (6), gently turn the *portafilter handle* (10) to the left to release it out from the *brew group* (9). Now put a filter basket into the portafilter (for one cup (a), for two cups (b)). Fill the basket with espresso grind using the measurement control of the espresso grinder. For a single shot, the basket will hold about 7 grams and a double 14 grams. Tamp the espresso grind, clean any grind remains from the edges of the basket and from the “bayonet mount”. Lock the portafilter back into the brew group.

5. Brewing the espresso

Place 1 or 2 cups under the *coffee spout* (11), and pull the lever downwards. Wait 7 to 12 seconds (pre-infusion time), until a few drops of espresso flow from the spout. Release the lever (8) carefully. The hot water is then pushed through the grind and your first foamy aromatic espresso will pour gently into your cup.

Caution!

Before taking off the *portafilter* (6), wait a moment, about 30 seconds, so that any remaining pressure can dissipate. If you want to continue making espresso, remove the *portafilter* (6), empty the used grind into a bowl, clean the *portafilter* (6) and repeat the procedure.

Although the espresso should be finely ground, it should not be too fine; otherwise, the espresso will flow very slowly. If the grind is too coarse, it will flow too quickly and no crema will be produced.

To keep your espresso velvety, even when preparing many cups of espresso, we suggest regularly cooling the *portafilter* (6) under running cold water, thereby minimizing any risk of overheating. When the water in the level indicator has reached the bottom line, the machine should be switched off immediately!

The boiler top (7) should under no circumstances be opened as long as the machine is on and the remaining pressure has not been released through the *steam tab* (3).

After the machine has been refilled, you can continue. Just follow steps 1 to 5.

Adjustment, maintenance and cleaning.

If you want to make espresso of the highest standard, it is essential to clean the machine on a daily basis and to have regular maintenance inspections!

The *steam wand* (12) needs to release the remaining steam after every use and to be cleaned with a damp cloth. To do this you open the *steam tab* (3) slightly.

The more calciferous the water, the more the boiler has to be descaled. We suggest you have your machine descaled by our local service-providers at least once a year. If you would prefer to do this yourself, we suggest you purchase a commonly used decalcifying solution for coffee machines and use it as described in the product manual.

To be energy efficient our Cremina has a so-called shut-down switch. This means that it switches itself off after 1 hour of non-use. Your Cremina can of course be switched on again afterwards.

We suggest a thorough clean of all the coffee baskets, to prevent the holes from becoming blocked. Use no dishwashing liquid for this. As soon as the basket holes get bigger or the baskets are squashed on the sides, we suggest exchanging them for new ones. After the baskets have been cleaned, we also recommend cleaning the inside of the portafilter. The *shower* (12), which sits in the *brew group* (9), is cleaned automatically through the daily cleaning of the brew group.

To check this, let the water flow out of the brew group without the portafilter attached. If the water flows consistently out of the shower, it is clean. However, if the water flows out inconsistently or splashes, even though it has been cleaned, it is most likely broken and needs to be replaced. The sealing gaskets hinder the splashing of water while in use, but needs to be changed as soon as water loss on the brew head is noticed. The loss of water reduces the amount of pressure, which is put on the coffee basket. This reduces the quality of the final product. The machine is fitted with a thermostatic safeguard, which hinders the burnout of the boiling element if the machine is in use without any water. If the safeguard has for some reason switched itself off, please let us, or our local service partner, know immediately.

Upon consultation you can of course also send us your Cremina, not only in the case of a defect, but also for its regular check-up. To do so, please order and use a big enough delivery box from us.

Steam.

Hot Water

You can also use the steam to boil water or make tea. To do this, open the brew tab (3) slightly to release condensed water or remaining air before starting. This will also prevent any suction of the fluid being heated up. Put the end of the steam nozzle (12) into the filled cup or a different container. Leave the steam tab opened until the desired temperature is reached. Then, close the tab again before removing the container or cup.

Hot milk without froth

Fill the milk froth container with milk; immerse the steam nozzle (12) in the milk. Now turn on the steam tab and turn it off again as soon as the desired temperature is reached. Close the tab first before pulling away the container; otherwise, the milk may splash out.

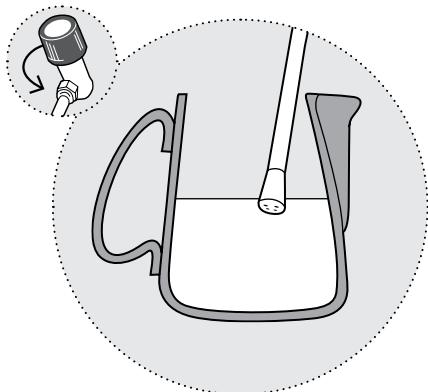

01 Pouring in the milk; immerse the steam nozzle in; open the steam tab

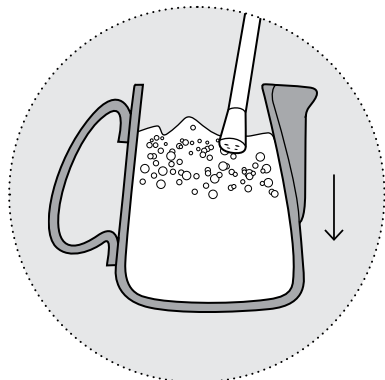

02 Steaming the milk; lower the container slightly («stretching»)

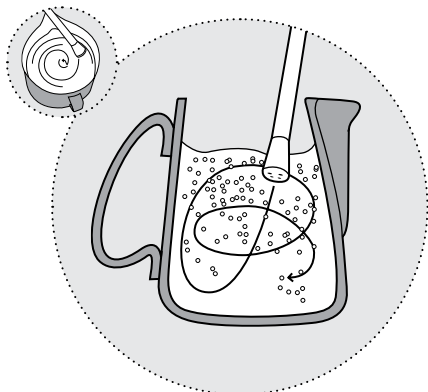
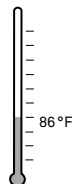

03 Mix the froth with the milk through rotation («rolling»)

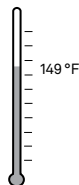

Hot milk with froth

The making of perfect milk froth comes in two steps, the so-called “stretching and rolling”. For the stretching phase, immerse the steam nozzle (13) into the milk and open the steam tab (3) fully. When the milk slowly starts to create froth, the container needs to be lowered slightly, whereby the tip of the steam wand always has to be slightly below the milk surface. When the volume has nearly doubled and reached 30°C/86°F, the rolling phase can start. The steam wand should be placed deeper into the milk to mix the created froth with the hot milk. Through rotation, the frothed milk will get finer and finer. The big bubbles burst and the mixture will form to be a homogeneous fluid. However, the milk must not become too hot. The ideal temperature can be checked by placing one hand on the container, if it is more than hand warm, but not hot, the optimal temperature of 65°C/149°F has been reached. Then, close the steam tab and remove the container.

Immediately after the use, release remaining steam from the steam wand and clean it with a damp cloth. By doing so, dirt and limestone will not build up around its tip or the inside.

03 Espresso.

The importance of the water.

The quality of the water used is very important for the preparation of a good espresso. It is important not to use hard water, so the taste and the aroma of the ground beans can fully unfold. The water hardness varies from region to region, depending on the potassium salts solved in it. A German hardness grade (°dh) complies with the content of 0.35oz limestone per 264.17 gallons of water. Many water filter manufacturers offer test cards, helping you to find out about the composition of your tap water and what hardness grade it is. We recommend a hardness grade from about 6°dh (US: 0.336 ppm CaCO₃) A normal water filter filters the limestone out of the water, so that the aroma of the espresso can unfold fully. Apart from the taste, there is also another reason why you should not use hard water. Limescale can cause crust formation in the pipes and the boiler and thus cause slow water flow. Limescale blockage can also cause a reduction in temperature of the outflowing water and thus affect the outcome.

The importance of the bean.

Most available coffee blends sold consist of two different coffee blends, which differentiate in taste, caffeine amount and shape. Arabica beans have a rounded cut in the middle, are longer and flatter. The unroasted beans have an intense green colour. The cut on the Robusta (or Canephora) bean on the other hand is very straight, it is rounder and it is a little lighter in colour with brown or grey shading. Whereas the Robusta bean has high caffeine content, the Arabica beans are milder and more aromatic. Even though common opinion suggests that pure Arabica blends are better than ones with a small proportion of Robusta beans, it should be noted that a small Robusta part (about 10%) intensifies the taste and the aroma; it also simplifies the espresso making procedure and compensates the traces of bitterness in Arabica beans. Even though the roasted beans are enclosed in vacuum or valve packages and do not lose their characteristics for many months, they are, however, at their best within the first 3-4 weeks. We suggest a dry and airy place for storage. Warmth, light and strong aromas are to be avoided. Espresso loses its aroma very quickly when exposed to air. Therefore, the packaging should only be opened just before filling it into the grinder. Because more taste is lost more quickly when the beans are grinded, only grind as much as you need.



01

02

01 Arabica bean: unroasted, roasted

02 Robusta / Canephora bean: unroasted, roasted

Perfect espresso in five steps.

The preparation

The espresso machine should be switched on 15 minutes before use, so that the right temperature exists in all parts of the machine and the needed pressure has built up. Since most parts only really heat themselves when the espresso is being made, we suggest putting the portafilter with basket, but without espresso into the brew group and letting water flow through by lowering und lifting lever.

The grinding

For the use of the grinder, please consider the advice offered to you in the owner's book of the grinder "Olympia Express Moca". The setting of the grinder is extremely important, since it can alter the size of the grind. If the beans have been ground too coarsely, the water will flow through the grind too quickly and not all the desired aromatic parts will have been extracted. The result is a thin espresso that is poor in aroma. However, if the grind is too fine, the water will run through the coffee very slowly and the espresso will taste wooden and bitter. Endless factors, such as humidity, air pressure and quality, blend and roast temperature of the bean are of such high importance to the outcome that there is not "the" right grind setting. The ideal grind setting is achieved when it takes 20–30 seconds to pull an espresso shot.

The dosage

After the grinding, it is important to fill the basket in the portafilter with the right amount of espresso (7.5 to 9gr / 0.27oz to 0.32 oz for a single and 14gr / 0.53oz for a double shot). Not following these guidelines would mean that the same problems might occur as with the too coarse or too fine espresso grind. Please pay attention to the right choice of basket. If you select the wrong one, the outcome can be frustrating. We recommend to always use the double basket for best result.

The tamping

The espresso in the portafilter basket has to be properly tamped down to provide the flowing water with the needed resistance: If the espresso is not tamped sufficiently, the water will run through the grind without picking up the entire aroma, if the espresso is tamped too hard, the water flow can be very slow or not happen at all. The suggested force to be tamping with is 15kg/33lb. With a little practice you will find out the perfect tamping pressure.

The extraction

After tamping, place the portafilter, which holds the basket, counter clockwise into the brew group. If water or coffee spills out from the sides when you pull the lever down, you have either put in too much espresso grind or the portafilter is sitting too loosely in the brew group. Once it has been tightened, push down the lever slowly, wait 7 to 12 seconds till a few drops fall from the spout, then carefully release the lever. The lever moves up steadily. The result will be an aromatic, delicious espresso with a beautiful hazel-coloured crema.

Judging the result.

If you have followed the instructions, the result is a perfect espresso. You can judge this by the following criteria:

The first impression

The colour of the crema shows the caramelized natural sugars of the espresso bean. Ideally, the crema should be of a hazel colour with shimmers of red irregular stripes (fig. 01). The crema should be three to four millimetres thick. It should not include any big bubbles and last a minimum of three minutes without breaking up or decomposing. If the crema is light, thin, contains big bubbles and disappears quickly, it is a sign of insufficient use of the espresso grind (fig. 02). If the crema is dark brown or black with a white spot, or it is too thin with the tendency to form a black hole in the middle, the espresso grind has been exhausted (fig. 03).

The aroma

The espresso flavour consists of many different substances. After the extraction of the shot(s), the aroma should be intense but pleasant and slightly sweet. The espresso should not be burned or taste wooden, smell musky or like tobacco. A touch of hazelnut can develop when a blend with a high Arabica percentage is used. An unclear, weak or lack of smell is a sign of poor use of the espresso. A biting, sour taste or too dominant smell means the espresso has been exhausted.

The taste

A perfect espresso needs no sugar, however, but sugar can complete it. The taste of the espresso should be perfectly balanced between sweet and bitter. It should never taste burnt or leave a bitter aftertaste. A watery tasting espresso without the needed density is normally due to badly brewed espresso.

A bitter tasting espresso with an intense taste and not much aroma plus an extreme aftertaste is normally the outcome of a too intensely brewed espresso grind.

- 01 Perfect crema
- 02 Light and thin crema
- 03 dark brown crema with black hole in the middle

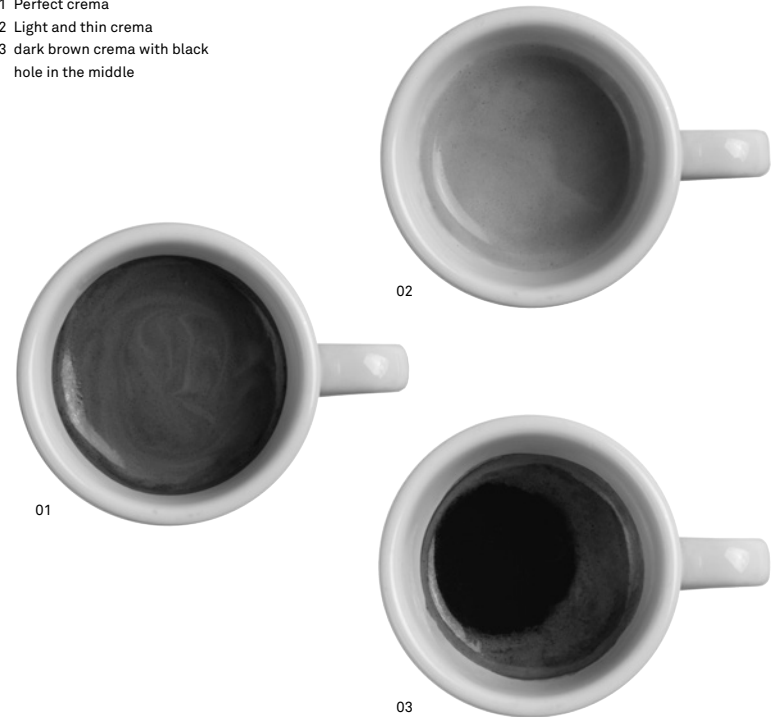

Espresso richness.

The Italian bar is a popular place to enjoy small refreshments: the obligatory espresso, which in Italy is simply called “caffè”, a glass of wine and of course hot debates about important or sometimes less important things. Here, one can find the biggest variety of coffee specialties. Have you ever tasted these?

Caffè americano

An espresso, which has been topped up with hot water.

Caffè brulot

Put brandy or cognac in a pre-warmed cup, place a sugar cube in the middle and light it. Pour the shot of espresso over and top off with some whipped cream.

Caffè creme

An espresso with a proper crema, but considerably more water. This is the Swiss’ favourite drink.

Caffè corretto

An espresso, with an added shot of brandy, aniseed schnapps or cordial.

Caffè doppio

A double espresso (about 1.69floz), served in an espresso cup.

Caffè freddo

A sweetened, espresso served cold.

Caffè latte

White coffee the Italian way. An espresso doppio and hot milk is served together in either a glass or a bowl, usually without froth.

Caffè macchiato

An espresso with a shot of frothed hot milk, a “maculate coffee” because the milk leaves a small white spot on the espresso. It is served hot in an espresso cup and looks just like a small cappuccino.

Caffè mischio

Espresso mixed with hot chocolate and served with whipped cream. An interesting alternative to latte macchiato.

Caffè moca

$\frac{1}{3}$ espresso, $\frac{1}{3}$ hot milk, $\frac{1}{3}$ hot chocolate. Caffè moca is served in a glass. It can be sweetened with sugar and served with whipped cream.

Caffè ristretto

An espresso that has been made with very little water. Mostly between 0.51oz and 0.76oz instead of the usual 0.85oz. Mainly drunk standing at the bar.

Caffè shakerato

An espresso drink that—either with or without sugar—is mixed in a cocktail shaker with ice cubes. Flavours such as vanilla or caramel can be added as well as a shot of grappa or amaretto.

Caffè sorbetto

Espresso that is frozen in ice cube trays and then be blended in a mixer with added sugar and milk. The outcome is a soft “mousse”, which is served in very cold glasses.

Cappuccino

1/3 espresso, 1/3 hot milk, 1/3 froth. Topped with chocolate or cinnamon, served in special cappuccino cups. The name cappuccino stems from the nutty-brown color, which reminds of the frocks worn by the “Capuchin” monks. Rumor has it that the cappuccino originated in Vienna. The Italians inherited the “Capuchin” and used milk froth rather than whipped cream.

Cappuccino chiaro

A cappuccino that is being prepared with less espresso and more hot milk.

Cappuccino scuro

A cappuccino that is being prepared with more espresso and less milk.

Cappuccino freddo

A cappuccino served cold “on the rocks”.

Frappuccino

An espresso mixed with sugar and cream. Fill into a cooled glass and add a few ice cubes. Basta!

Latte macchiato

A latte macchiato is served in a glass; at the bottom of the glass is the hot milk, in the middle the espresso and on top the colder milk froth.

04 First aid and more.

Troubleshooting with possible disorders.

Inadequately brewed espresso grind

Appearance: Light, watery, coarse bubbled froth, thin crema and quickly disappearing aroma.

Reason	Suggested Solution
Espresso too coarse	Grind the espresso finer
Espresso amount too little	Increase the amount of espresso ground
Espresso tamped either too little or not at all	Tamp the espresso harder
Water temperature below 190.4 °F	Reset Boiler
The espresso flows out too quickly (extraction time below 20 seconds)	Check the temperature and the pressure; if o.k., grind the espresso finer. Increase the espresso amount and/or tamp harder

Overbrewed espresso grind

Appearance: Foam is dark or black, with a white spot or a black hole in the middle, very thin, which dissolves towards the edge of the cup. Taste is bitter without any aroma.

Reason	Suggested Solution
Espresso ground too fine	Espresso needs to be ground more coarsely
Espresso amount above 0.35 oz	Set the amount between 0.26 – 0.32 oz
Espresso tamped too hard	Espresso needs to be tamped more softly
Water temperature above 197.6 °F	Water pressure needs to be reset by engineer
Espresso only drips out of the spout (extraction time over 30 seconds)	Check temperature and pressure; if o.k., grind the espresso coarser, reduce amount and/or tamp slightly softer

Problem	Reason	Solution
No aroma	Poorly coffee beans	Do not stock too much at once Open coffee beans packaging only before use Do not grind too much at once
Oily bubbles on the crema	Grinding burs are blocked up or worn out	Clean the grinding burs or replace them
Unsatisfactory espresso taste	Encrusted filter Blocked portafilter Dirty shower	Clean and service the espresso machine regularly
The machine, its control lamp and on/off switch do not work	No power	Check the fuse The cable is not plugged in properly
	On/off button defect	Replace the on/off button
The control lamp lights up, but the water does not heat up	Shut-down switch has heating switched off after 60 minutes	Set On/Off switch to On
	Thermostat safeguard switched boiler off	Send the machine in for repair
	Heating element is broken	Replace the heating element
Machine does not release any steam	Steam nozzle is blocked	Clean nozzle with the help of a thin needle
Machine is working but no espresso is flowing out	No water in the boiler	Refill water
	Espresso grind too fine	Check grinder
	Too much espresso in the portafilter basket	Check amount of espresso used
Espresso flows out of the side of the portafilter	Portafilter is not inserted properly	Inspect portafilter
	Too much espresso in the basket	Check the amount of espresso
	The edge of the portafilter is dirty	Clean the edge of the portafilter
	Gasket is blocked	Replace gasket

Ideas and suggestions.

When developing our products, we at Olympia Express think first and foremost about the needs and wishes of our customers. Hence, if you have any ideas or would like to make suggestions or tell us about your experiences with this machine—be they positive or negative—, we would look forward to hearing from you. Have you had a special experience that connects you with your machine? Share your story with other Olympia Express connoisseurs! We will publish the most pleasant and interesting ones on our website.

Best wishes from Switzerland,

Your Olympia Express-Team

If you would like to find out more about new and exciting Olympia Express products, please visit our website www.olympia-express.ch

Manufacturer:
Olympia Express SA
Sernfthalstrasse 34b
8762 Schwanden
SCHWEIZ

T +41 91 646 15 55

F +41 91 646 15 69

info@olympia-express.ch
www.olympia-express.ch

The manufacturer reserves the right to make changes to the described characteristics, performance, technical data and accessories may be made. Olympia Express continuously develops all models and types further.

All rights reserved. "OLYMPIA EXPRESS" and "CREMINA" are registered trademarks of Olympia Express SA.

Copyright 2020 Olympia Express SA

Control elements Interior view

- 16 Safety valve
- 17 Pressure switch
- 18 Boiler

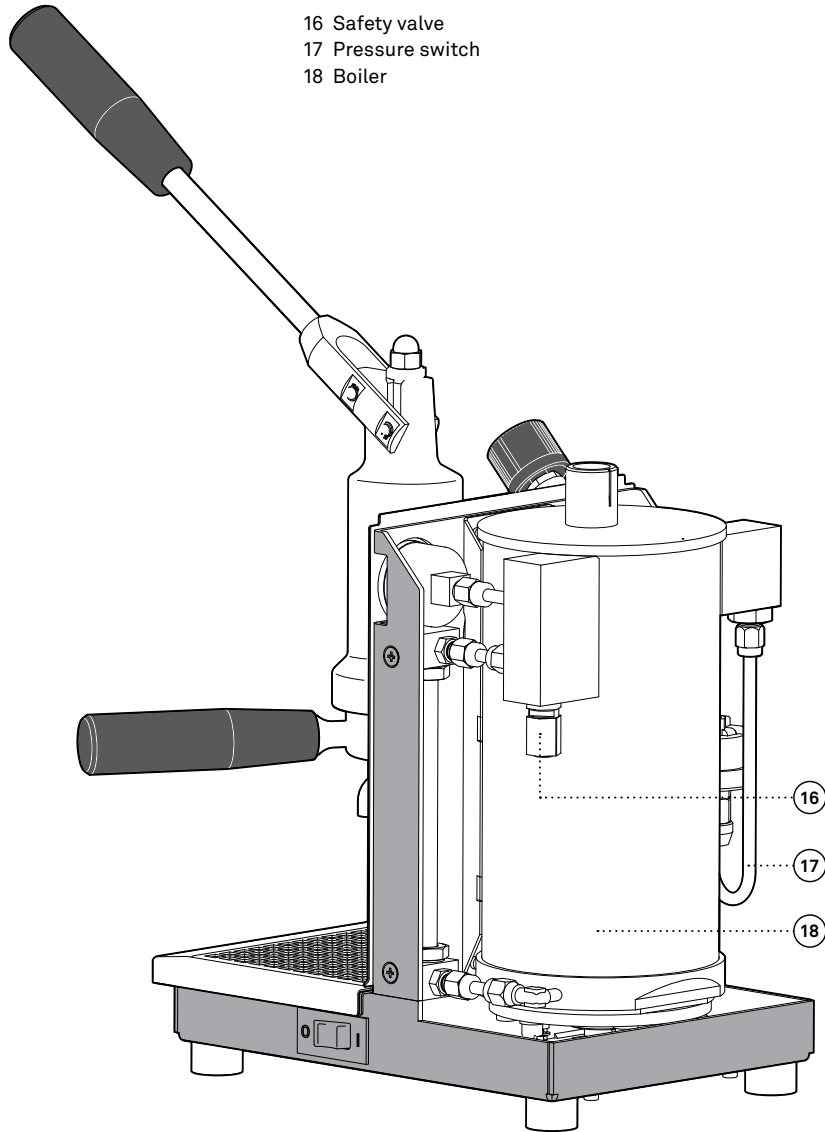

Control elements Front view

- 1 Boiler top
- 2 Water level indicator
- 3 Steam tab
- 4 On/Off button
- 5 Control lamp
- 6 Portafilter
- 7 Pressure gauge
- 8 Lever
- 9 Brew group
- 10 Portafilter handle
- 11 Spout
- 12 Steam wand
- 13 Steam nozzle
- 14 Drip tray
- 15 Shower (Part of the brew group)

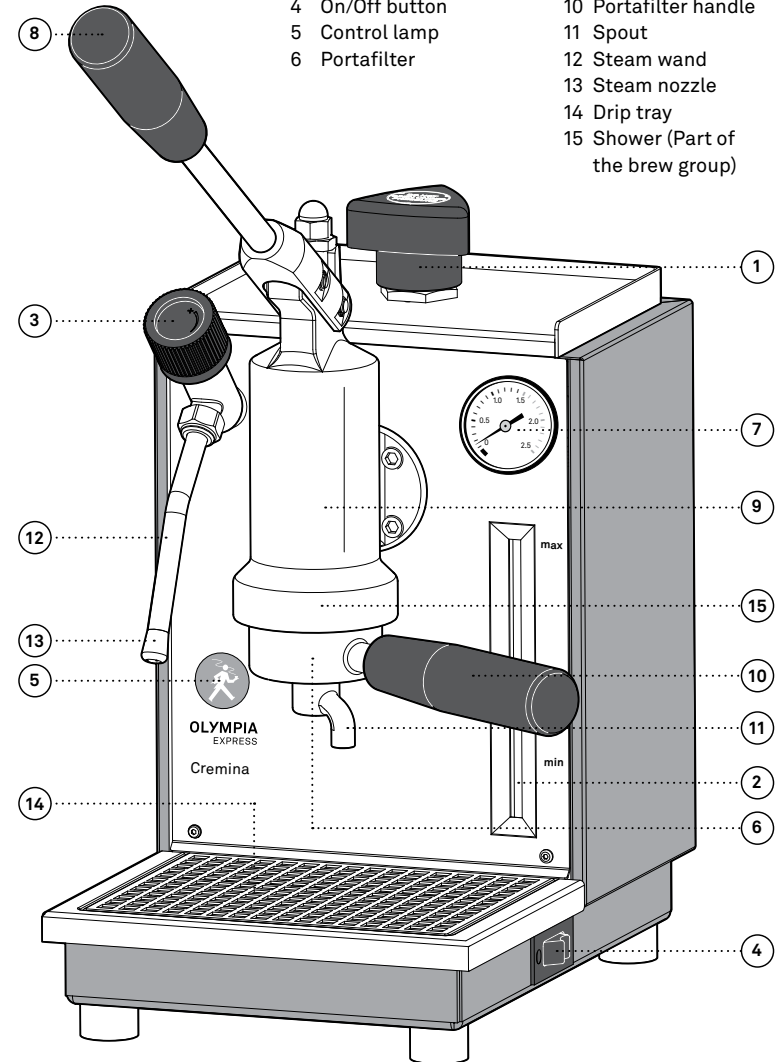

Disposal / Recycling.

The card box and packaging material are made entirely of environmentally friendly materials. They can be disposed of in your local recycling bins.

We recommend you to keep the original packaging for the case you need to transport the espresso machine.

Before you dispose a Olympia Express machine make inquiries whether there is a possibility to maintain or repair the machine. Olympia Express machines older than 50 years can be maintained and repaired due to the robust design.

The symbol of the crossed out bin on wheels signals that in the European Union the product must be disposed of in separated waste. This applies for the product and all accessory parts marked with this symbol. Marked products may not be disposed of in normal household waste, but must be taken to a recycling center for electric and electronic devices.

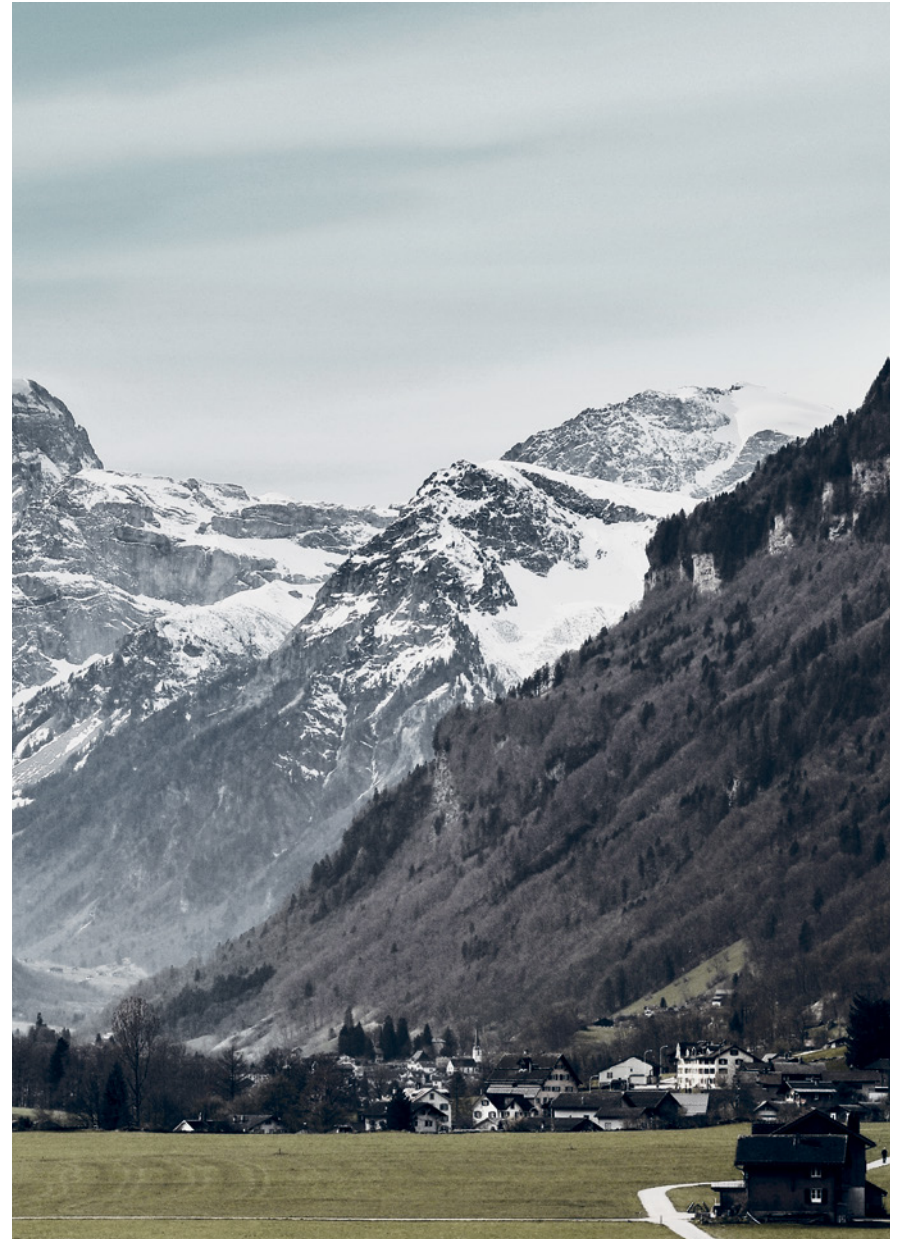

A decision for a lifetime. Olympia Express is a Swiss manufacturer of exclusive espresso machines and grinders. Looking back at an 90-year-old tradition of product development and craftsmanship, the small, yet fine company is among the pioneers on the market for premium espresso machines. The engineers and mechanics still live the spirit of the founder and pay close and loving attention to even the smallest of details. They work with passion and Swiss precision. The use of first class materials and components developed by Olympia Express results in compact machines and grinders with a noble look, unique quality and an extraordinary longevity. Hand made and Swiss made—the precondition for pure espresso delight.

Please visit our website:
www.olympia-express.ch

Swiss manufacturer of finest espresso machines.



SWISS MADE